

LOC		DIST		REV		REV		REVISIONS		DATE	APPD
AD	00	P	F	ZONE	LTR	NO	DESC	DATE	APPD		
				5			REV PER 063C-0520-04	11NOV04	JR/DS		

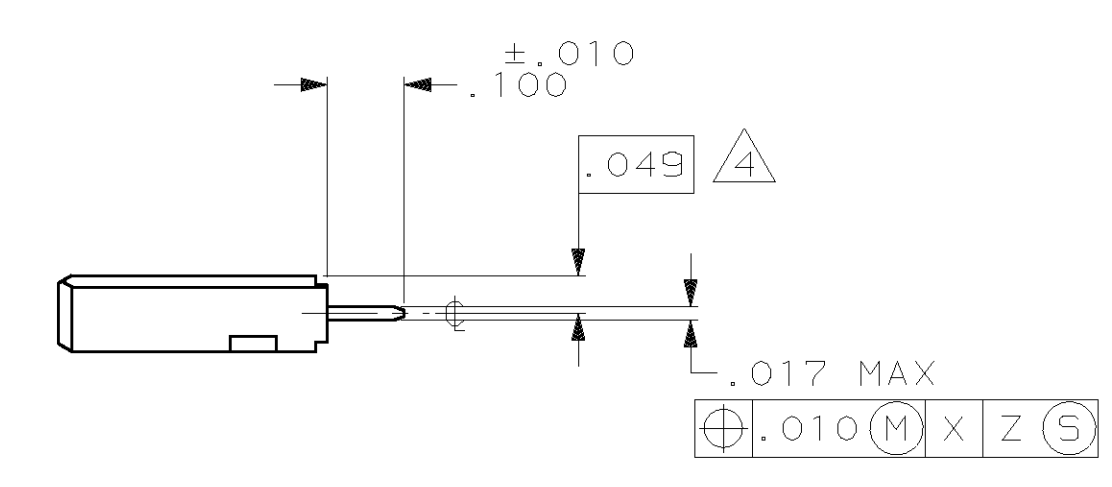

- 1 CONTACT AREAS PLATED WITH .000030 GOLD, SOLDER TAILS PLATED WITH .000150 TIN-LEAD, ALL OVER .000050 NICKEL
- 2 POINT OF MEASUREMENT FOR GOLD THICKNESS IS .030 FROM MATING END OF CONTACT
- 3 PRELIMINARY PART - NOT RELEASED FOR PRODUCTION.
- 4 THE NOTED DIMENSIONS APPLY AT THE INTERSECTION OF THE POST AND HOUSING.
- 5 CONTACT AREAS PLATED WITH .000030 GOLD, SOLDER TAILS PLATED WITH .000150 TIN, ALL OVER .000050 NICKEL

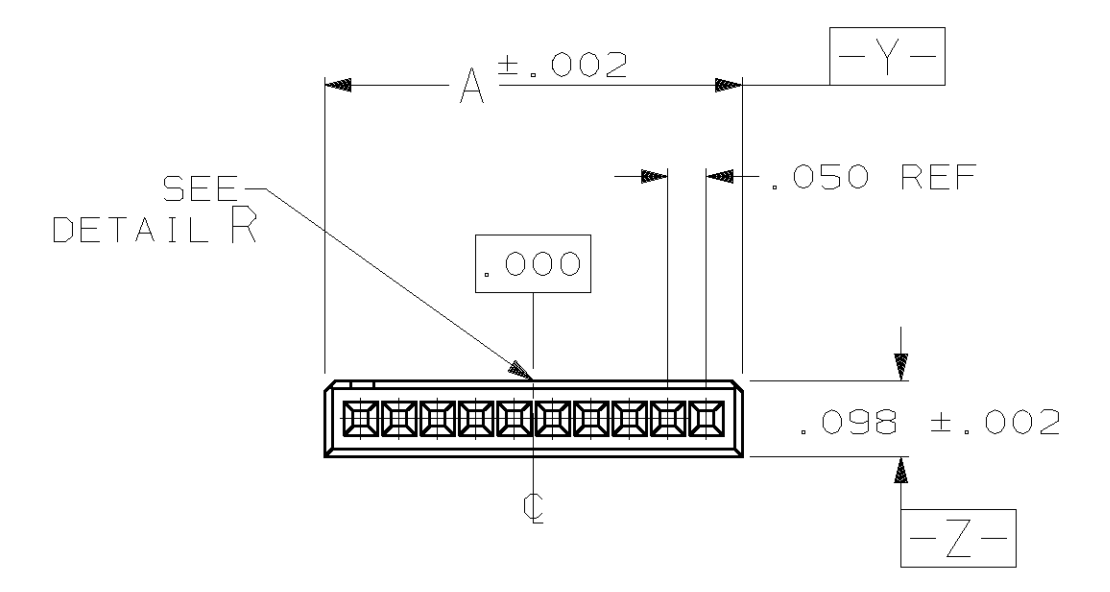
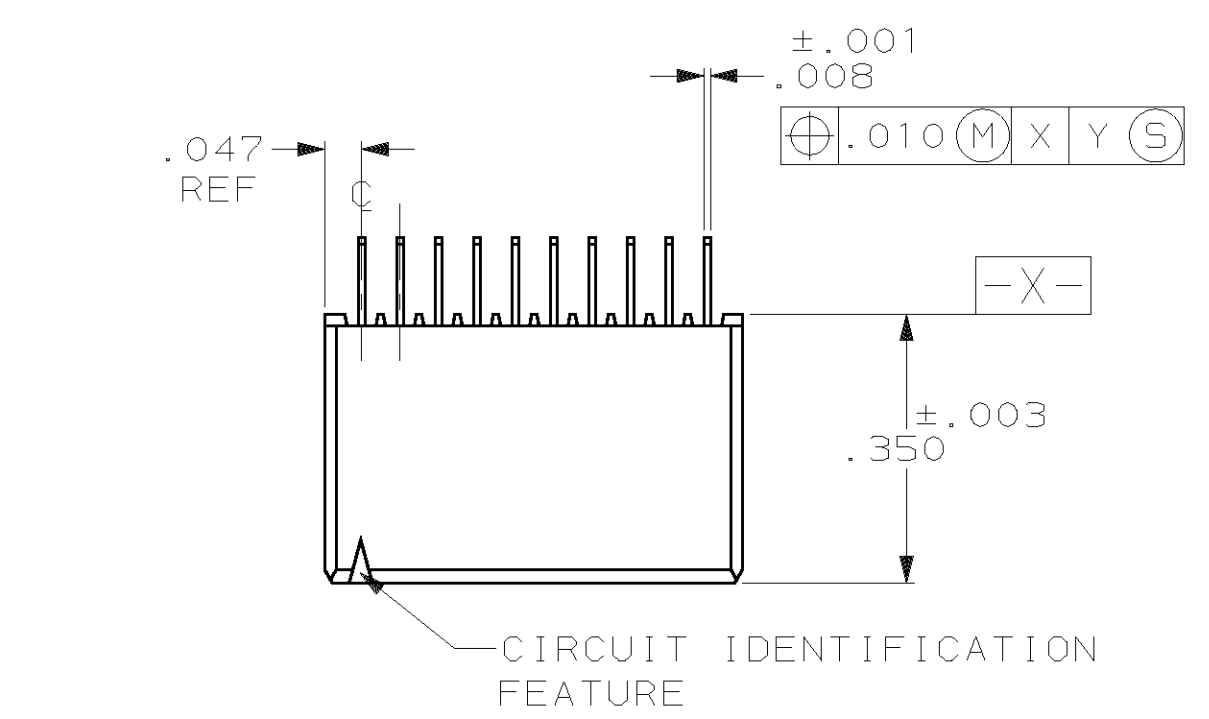
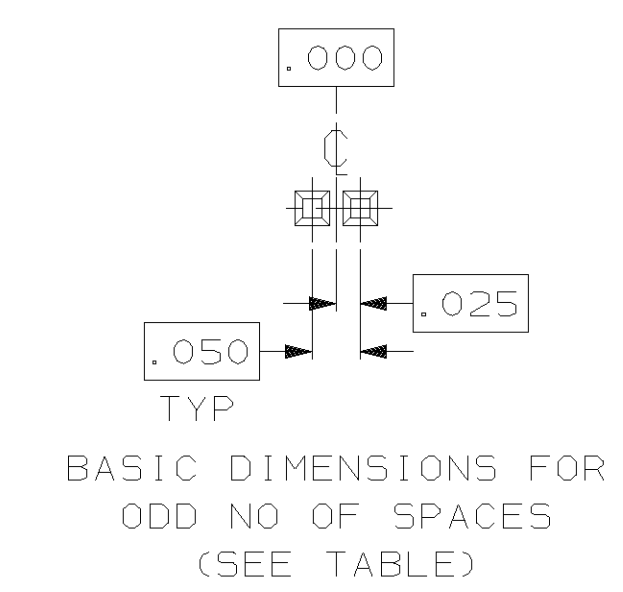
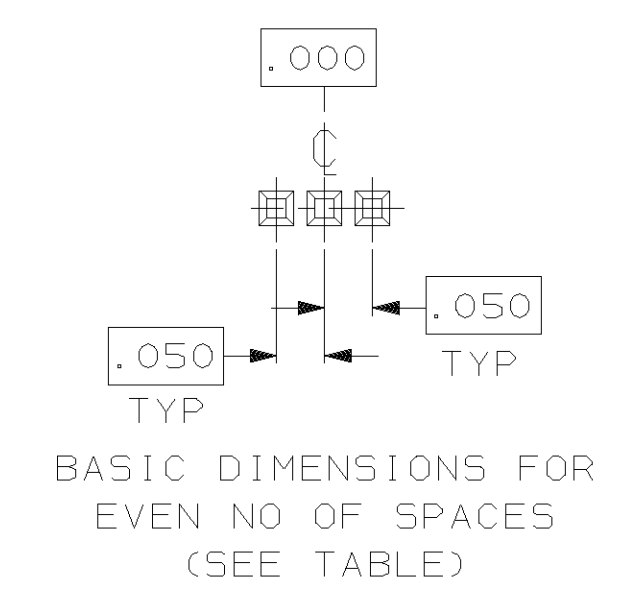
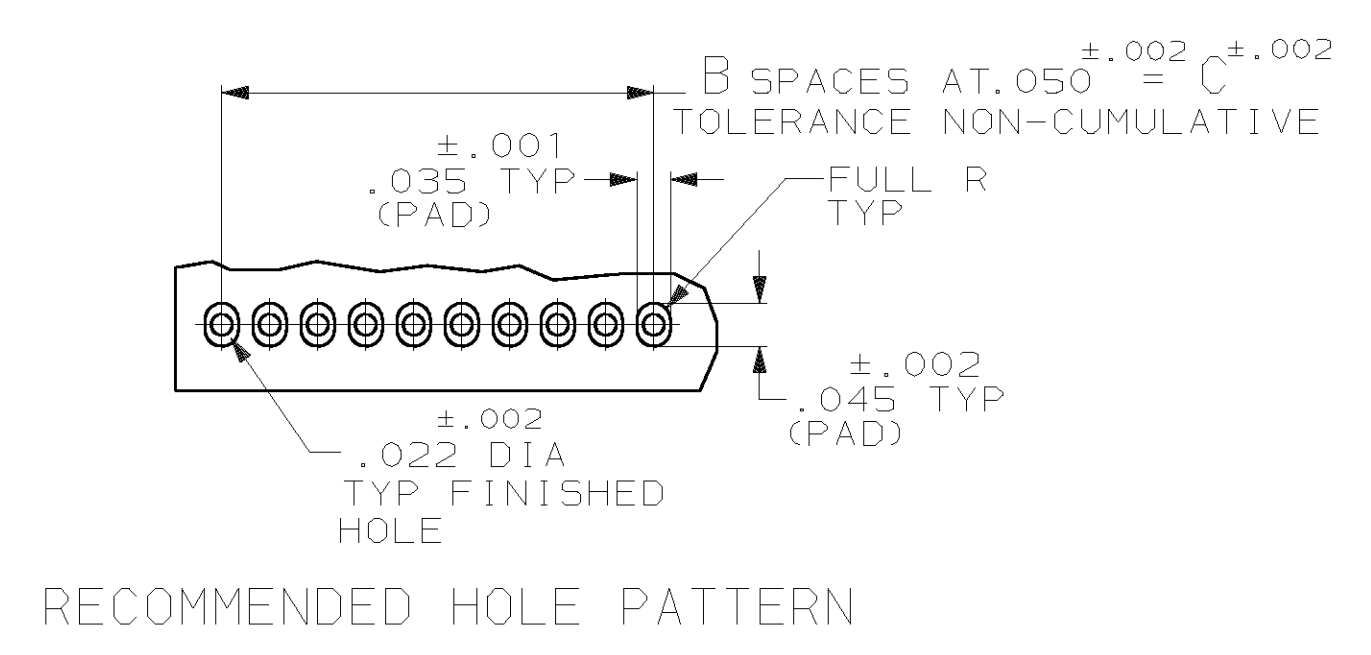

DETAIL R

NO OF POSN	C	B	A	NO OF POSN	PART NUMBER
25	1.250	25	1.344	26	6-104192-0
13	.600	13	.694	13	5-104192-9
4	.200	4	.294	5	5-104192-8
29	1.450	29	1.544	30	5-104192-7
24	1.200	24	1.294	25	5-104192-6
19	.950	19	1.044	20	5-104192-5
14	.700	14	.794	15	5-104192-4
11	.550	11	.644	12	5-104192-3
9	.450	9	.544	10	5-104192-2
7	.350	7	.444	8	5-104192-1
25	1.250	25	1.344	26	1-104192-0
13	.600	13	.694	13	104192-9
4	.200	4	.294	5	104192-8
29	1.450	29	1.544	30	104192-7
24	1.200	24	1.294	25	104192-6
19	.950	19	1.044	20	104192-5
14	.700	14	.794	15	104192-4
11	.550	11	.644	12	104192-3
9	.450	9	.544	10	104192-2
7	.350	7	.444	8	104192-1

DO NOT SCALE PRINT. UNLESS SPECIFIED DIMENSIONS IN INCHES TOLERANCES ON:		DR 10-3-88 D. CLOUSER		AMP INCORPORATED Harrisburg, Pa. 17105	
2 PLC DEC ± .005		CHK 10-3-88 T. ZOLA			
3 PLC DEC ± .005		APPD 10-3-88 T. ZOLA		NAME	
ANGLES ± -		APPD 10-3-88 C. SNYDER		RECEPTACLE ASSEMBLY, VERTICAL, SINGLE ROW, AMPMODU® System 50	
MATERIAL		PRODUCT SPEC		SIZE	
HOUSING: THERMOPLASTIC COLOR - BLACK		108-1093		FSCM NO	
POST: COPPER ALLOY		APPLICATION SPEC		DRAWING NO	
FINISH		114-25031		D 00779	
SEE TABLE		WEIGHT		SCALE 4:1	
				104192	
				SHEET 1 OF 1	